

MV-XC410-7050D is a Crystal Oscillator (XO) . This XO provides low jitter performance, CMOS output and comes in a Hermetic Ceramic 7.0x5.0mm package. This device contains an internal voltage regulator resulting in excellent power supply rejection ratio.

The device is qualified to meet the JEDEC standard for Pb-Free assembly and compliant to the RoHS directive.

Electrical Performance

Parameter	Min	Typ	Max	Units	
General					
Output Frequency		32.8		kHz	
Operating Temperature	-10/+70	-40/+85	-40/+105	-40/+125	°C
Stability Over Temperature		±50		ppm	
Aging			±3.0	ppm/year	
Start Up Time			5	ms	
Package Size		7.0 x 5.0 x 1.7		mm	
Supply					
Supply Voltage (Vdd)	3.14	3.3	3.47	V	
Supply Current		126	168	µA	
Current, Output Disabled			3	µA	
Output					
Output Signal		CMOS			
Output Logic Level					
Output Level - Logic High	Vdd x 0.9			V	
Output Level - Logic Low			Vdd x 0.1	V	
Output Load		15 - 30 pF			
Output Rise and Fall Time		18	21	ns	
Duty Cycle	45		55	%	
Enable / Disable					
Output Enable / Disable					
Output Enabled	Vdd x 0.7			V	
Output Disabled			Vdd x 0.3	V	

Notes:

- 1 Stability includes initial accuracy, operating temperature, supply voltage, shock and vibration (not under operation) and aging
- 2 Rise and Fall times measured from 20% to 80% of a full output swing
- 3 Power Supply pin should be filtered. e.g. 0.1µF or 0.01 µF Capacitor for optimal performance.
- 4 The Output is Enabled if the Enable/Disable is left open.

Maximum Ratings

Storage Temp	-55°C to 125°C
Supply Voltage	-0.5V to +7.0V
Enable/Disable Voltage	-0.5V to Vdd+0.5V
Junction Temperature	+150 °C

Maximum Ratings Notes:

- 1 Stresses in excess of the absolute maximum ratings can permanently damage the device.
- 2 Exposure to absolute maximum ratings for extended periods may adversely affect device reliability.

Package Information

Pin #	Function
Pin 1	E/D = Enable / Disable
Pin 2	GND = Ground
Pin 3	OUT = Output
Pin 4	Vdd = Supply Voltage

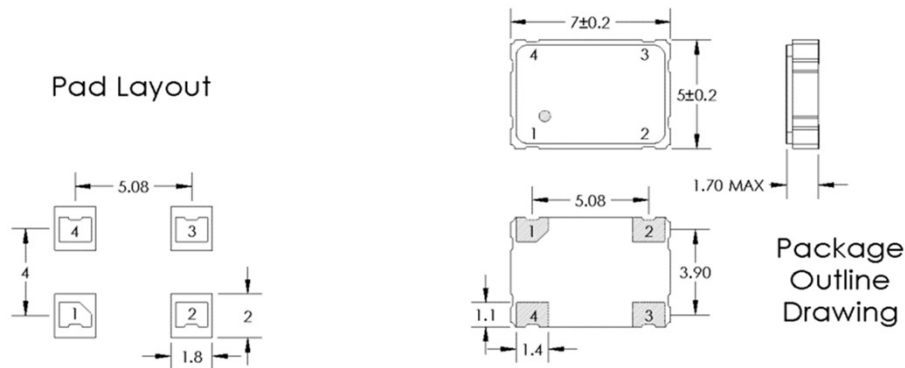
Handling and Construction

Package Construction	Hermetic Ceramic
Contact Pads	Gold over Nickle
Pad Metal Thickness	Gold (0.3µm min - 1.0µm max) over Nickel
Moisture Sensitivity Level	MSL 1
ESD, Human Body Model	1500V
ESD, Charge Device Model	1500V

Ordering Information
MV-XC410-7050D - x x C 1 - 32K76800

XO, CMOS

7.0 x 5.0 x 1.7mm, 4 Pins

① ② ③ ④

Frequency

① Voltage

 B: 3.3 V
 D: 2.5 V
 E: 1.8 V

② Temp Range

 J: -10/+70 °C
 K: -40/+85 °C
 L: -40/+105 °C

③ Temp Stability

C: ±50 ppm

④ Enable

1: Enable on Pin 1