

MV-XC261-7050D is a Crystal Oscillator (XO) . This XO provides low jitter performance, CMOS output and comes in a Hermetic Ceramic 7.0x5.0mm package. This device contains an internal voltage regulator resulting in excellent power supply rejection ratio.

The device is qualified to meet the JEDEC standard for Pb-Free assembly and compliant to the RoHS directive.

Electrical Performance

Parameter	Min	Typ	Max	Units
General				
Output Frequency	40		135	MHz
Operating Temperature	-10/+70 -40/+85 -40/+105 -40/+125			°C
Stability Over Temperature	±100 ±50 ±25 ±20			ppm
Start Up Time			10	ms
Package Size	7.0 x 5.0 x 1.7			mm
Supply				
Supply Voltage (Vdd)	3.14	3.3	3.47	V
Supply Current				
≤ 105 MHz		10	19	mA
> 105 MHz		13	25	mA
Supply Voltage (Vdd)	2.38	2.5	2.63	V
Supply Current				
≤ 105 MHz		9	16	mA
> 105 MHz		12	19	mA
Current, Output Disabled			20	µA
Output				
Output Signal	CMOS			
Output Logic Level				
Output Level - Logic High	Vdd-0.45		Vdd	V
Output Level - Logic Low			0.45	V
Output Load		15 pF		
Output Rise and Fall Time		1.5	3.0	ns
Duty Cycle	45	50	55	%
Enable / Disable				
Output Enable / Disable				
Output Enabled	Vdd x 0.7			V
Output Disabled			Vdd x 0.3	V
Phase Noise & Jitter				
Phase Noise: (125MHz)				
10 Hz offset		-70		dBc/Hz
100 Hz offset		-106		dBc/Hz
1kHz offset		-133		dBc/Hz
10kHz offset		-148		dBc/Hz
100kHz offset		-152		dBc/Hz
1MHz offset		-159		dBc/Hz
10MHz offset		-160		dBc/Hz
Jitter				
RMS Jitter: (12kHz - 20MHz) - 125MHz		0.08		ps

Notes:

- 1 Stability includes initial accuracy, operating temperature, supply voltage, shock and vibration (not under operation) and aging
- 2 Rise and Fall times measured from 20% to 80% of a full output swing
- 3 Power Supply pin should be filtered. e.g. 0.1µF or 0.01 µF Capacitor for optimal performance.
- 4 The Output is Enabled if the Enable/Disable is left open.

Maximum Ratings

Storage Temp	-55°C to 150°C
Supply Voltage	-0.3V to +4.0V
Enable/Disable Voltage	-0.3V to Vdd+0.3V
Junction Temperature	+150 °C

Maximum Ratings Notes:

- 1 Stresses in excess of the absolute maximum ratings can permanently damage the device.
- 2 Exposure to absolute maximum ratings for extended periods may adversely affect device reliability.

Package Information

Pin #	Function
Pin 1	E/D = Enable / Disable
Pin 2	GND = Ground
Pin 3	OUT = Output
Pin 4	Vdd = Supply Voltage

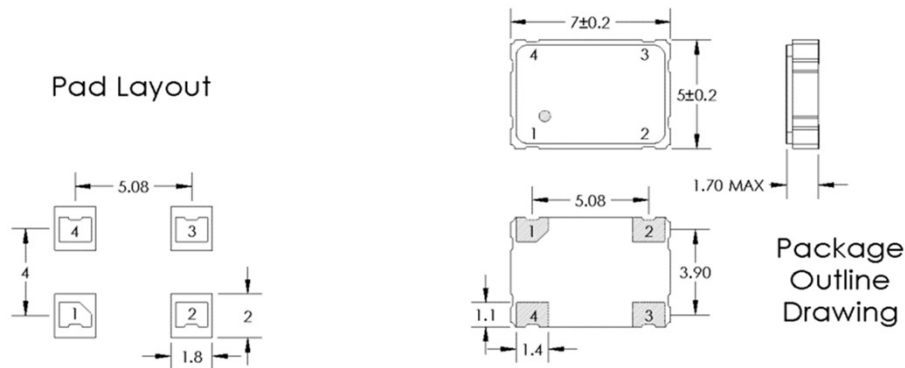
Handling and Construction

Package Construction	Hermetic Ceramic
Contact Pads	Gold over Nickle
Pad Metal Thickness	Gold (0.3µm min - 1.0µm max) over Nickel
Moisture Sensitivity Level	MSL 1
ESD, Human Body Model	1500V
ESD, Charge Device Model	1000V

Ordering Information

MV-XC261-7050D - x x x 0 - xxMxxxxx

XO, CMOS

7.0 x 5.0 x 1.7mm, 4 Pins

① ② ③ ④

Frequency

① Voltage

B: 3.3 V
D: 2.5 V
E: 1.8 V

② Temp Range

J: -10/+70 °C
K: -40/+85 °C
L: -40/+105 °C

③ Temp Stability

A: ±100 ppm
C: ±50 ppm
E: ±25 ppm
F: ±20 ppm

④ Other

0: Standard